

## 5mm CERAMIC TRIMMER CAPACITORS SPECIFICATIONS

### 1. Applications

These specifications are applied to Ceramic Trimmer Capacitors with ceramic dielectric, which are used for the electric and electronic apparatus and communication equipments.

### 2. Part number

The part number consists of category, dimension , temperature characteristics and maximum nominal capacitance :

$$\frac{CVN}{(a)} \quad \frac{5}{(b)} \quad \frac{100}{(c)} \quad (100 \text{ is } 10 \times 100^0 = 10 \text{ PF})$$

- (a) Category : Ceramic Trimmer Capacitor
- (b) Outer size : Open Type :φ5mm
- (c) Maximum nominal capacitance : PF unit in 3 digits (The 1st and 2nd digit indicate the significant figures, and the 3rd indicate the number of naught.)

**3. Rated voltage** : 100VDC

**4. Temperature range** : -25°C to +85°C

### 5. Test circumstance

Test should be done at 20°C with relative humidity at 65%. However, subjected to special requirement, the ideal range should be within ±5°C and humidity from 45°C to 85°C

### 6. Electrical Characteristic

#### 6.1 Capacitance

When measured at 20°C, 0.5V to 5V, and 1MHz ,the minimum capacitance is smaller than the minimum nominal capacitance and the maximum capacitance is bigger than the maximum normal capacitance. Please refer to the minimum and maximum capacitances listed at the attached specifications.

## **6.2 Temperature Characteristics**

The ideal temperature coefficient of the capacitance shall be between  $-25^{\circ}\text{C}$  and  $85^{\circ}\text{C}$ .

## **6.3 Q (Quality factor)**

When measured at  $20^{\circ}\text{C}$ , 0.5V to 5V, 1MHz and maximum capacitance, the Q values given at the attached specification.

## **6.4 Insulation Resistance**

When applied 100VDC between terminals for 1 minute at maximum capacitance, the insulation resistance shall be more than  $10,000\text{M}\Omega$ . (apply under max.cap 60pf)

## **6.5 Withstanding Voltage**

Applied 220VDC (less than 5mA) for 5 seconds between terminals, no defect was found.

# **7. Structure and mechanical characteristics**

## **7.1 Configuration and Dimensions**

Please refer to the attached drawings.

## **7.2 Strength of Terminals**

When applied a power to the terminals to any direction slowly and kept at 0.25 kg for 10 seconds, the terminals shall not be loosen or broken mechanically.

## **7.3 Torque**

The torque test should be done at least for 1 round tuning from 35gf.cm to 200gf.cm for the normal type or 15gf.cm to 150gf.cm for the Reverse Type. Please note that it might cause the torque will decrease against the rotation increase.

## **7.4 Solder ability**

When dipped the terminals into the soldering pot at  $255^{\circ}\text{C} \pm 5^{\circ}\text{C}$  for  $2 \pm 0.5$  seconds, There is almost 75% of the total dipped surface are covered with the new solder.

# **8. Color Code**

Color code is not applicable for this series

**5 mm Ceramic Trimmer Capacitors**

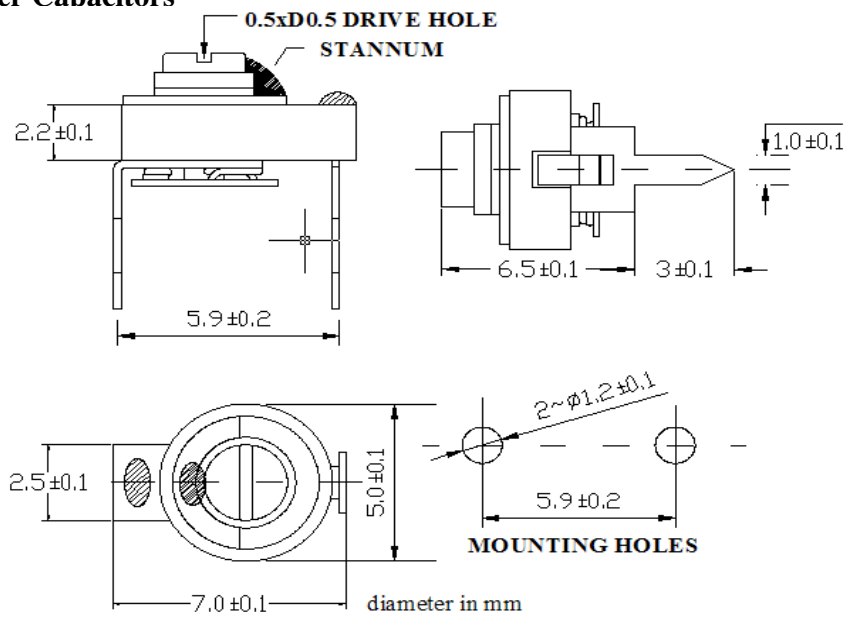

Part No.	Capacitance(pF)			Q (1MHz, Cmax)	Temp.Coeff ppm/°C	Remarks
	Min	Max.				
CVN 5020	1.3 max	2	+ 50% - 0%	300 min	NP 0±250	
CVN 5030	1.5 max	3	+ 50% - 0%			
CVN 5050	2.0 max	5	+ 50% - 0%			
CVN 5100	3.0 max	10	+ 50% - 0%		N 750±250	
CVN 5200	4.5 max	20	+ 50% - 0%			
CVN 5300	5.5 max	30	+ 50% - 0%	200 min	N 1000±500	
CVN 5400	6.8 max	40	+ 50% - 0%			
CVN 5500	9.8 max	50	+ 50% - 0%		N 2200±800	
CVN 5600	12.0 max	60	+ 50% - 0%			
CVN 5700	14.0 max	70	+ 50% - 0%			